

# CrystalLink USB-3-2-1 CATx

USB3.1/2.0/1.1 CAT6a/7 Extender

## Installation and Operation Manual



# LIMITED WARRANTY

---

---

Rose Electronics® warrants the CrystalLink USB-3-2-1 CATx Extender to be in good working order for one year from the date of purchase from Rose Electronics or an authorized dealer. Should this product fail to be in good working order at any time during this one-year warranty period, Rose Electronics will, at its option, repair or replace the Unit as set forth below. Repair parts and replacement units will be either reconditioned or new. All replaced parts become the property of Rose Electronics. This limited warranty does not include service to repair damage to the Unit resulting from accident, disaster, abuse, or unauthorized modification of the Unit, including static discharge and power surges.

Limited Warranty service may be obtained by delivering this unit during the one-year warranty period to Rose Electronics or an authorized repair center providing a proof of purchase date. If this Unit is delivered by mail, you agree to insure the Unit or assume the risk of loss or damage in transit, to prepay shipping charges to the warranty service location, and to use the original shipping container or its equivalent. You must call for a return authorization number first. Under no circumstances will a unit be accepted without a return authorization number. Contact an authorized repair center or Rose Electronics for further information.

ALL EXPRESS AND IMPLIED WARRANTIES FOR THIS PRODUCT INCLUDING THE WARRANTIES OF MERCHANTABILITY AND FITNESS FOR A PARTICULAR PURPOSE, ARE LIMITED IN DURATION TO A PERIOD OF ONE YEAR FROM THE DATE OF PURCHASE, AND NO WARRANTIES, WHETHER EXPRESS OR IMPLIED, WILL APPLY AFTER THIS PERIOD. SOME STATES DO NOT ALLOW LIMITATIONS ON HOW LONG AN IMPLIED WARRANTY LASTS, SO THE ABOVE LIMITATION MAY NOT APPLY TO YOU.

IF THIS PRODUCT IS NOT IN GOOD WORKING ORDER AS WARRANTIED ABOVE, YOUR SOLE REMEDY SHALL BE REPLACEMENT OR REPAIR AS PROVIDED ABOVE. IN NO EVENT WILL ROSE ELECTRONICS BE LIABLE TO YOU FOR ANY DAMAGES INCLUDING ANY LOST PROFITS, LOST SAVINGS OR OTHER INCIDENTAL OR CONSEQUENTIAL DAMAGES ARISING OUT OF THE USE OF OR THE INABILITY TO USE SUCH PRODUCT, EVEN IF ROSE ELECTRONICS OR AN AUTHORIZED DEALER HAS BEEN ADVISED OF THE POSSIBILITY OF SUCH DAMAGES, OR FOR ANY CLAIM BY ANY OTHER PARTY.

SOME STATES DO NOT ALLOW THE EXCLUSION OR LIMITATION OF INCIDENTAL OR CONSEQUENTIAL DAMAGES FOR CONSUMER PRODUCTS, SO THE ABOVE MAY NOT APPLY TO YOU. THIS WARRANTY GIVES YOU SPECIFIC LEGAL RIGHTS AND YOU MAY ALSO HAVE OTHER RIGHTS WHICH MAY VARY FROM STATE TO STATE.

# DECLARATIONS OF CONFORMITY

---

---

This is to certify that, when installed and used according to the instructions in this manual, the units listed and described here are shielded against the generation of radio interferences in accordance with the application of Council Directives 2014/30/EU and 2014/30/EU, as well as these standards:

- EN 55022: 2010/AC:2011 (Class B)
- EN 55024:2010 + A1:2015
- EN 55032
- EN 61000

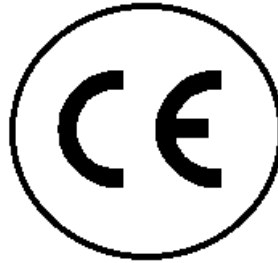

This equipment has been found to comply with the limits for a Class A digital device, pursuant to Part 15 of the FCC Rules. These limits are designed to provide reasonable protection against harmful interference when the equipment is operated in a commercial environment. This equipment generates, uses, and can radiate radio frequency energy and, if not installed and used in accordance with the instruction manual, may cause harmful interference to radio communications. Operation of this equipment in a residential area is likely to cause harmful interference in which case the user will be required to correct the interference at their own expense.

The product safety of the devices is proven by their compliance with the following standards:

- CAN/CSA-ICES-003 Issue 6

The manufacturer complies with the EU Directive 2012/19/EU on the prevention of waste electrical and electronic equipment (WEEE). The device labels carry a respective marking.

These devices comply with Directive 2011/65/EU of the European Parliament and of the council of 8 June 2011 on the restriction of the use of certain hazardous substances in electrical and electronic equipment (RoHS 2, RoHS II). The device labels carry a respective marking.

# TABLE OF CONTENTS

---

---

## Contents

Disclaimer	1
System Introduction	1
Features	1
Package Contents	2
Additional Items Required	2
Application Examples	2
CrystalLink USB-3-2-1 CATx Models	3
Transmitter Unit	3
Receiver Unit	4
Installation Procedure	6
Cabling Requirements	6
Equipment Location	7
Installing the Transmitter	7
Installing the Receiver	8
Connecting the Transmitter to the Receiver	8
Checking the Installation	8
Connecting a USB Device	9
Compatibility	9
Ethernet Pass-Through Connection	9
Transmitter and Receiver Mounting Options	10
Option 1: Crystallink USB-3-2-1 CATx Extender Mounting Bracket Kit	10
Option 2: Crystallink USB-3-2-1 CATx Extender Mounting Plate	10
Troubleshooting	11
Safety	14
Maintenance and Repair	15
Technical Support	15

## Figures

Figure 1. transmitter unit - LED's and connectors	4
Figure 2. Receiver unit - LED's and connectors	5
Figure 3. CrystalLink USB-3-2-1 CATx extender - standard installation	6
Figure 4. Installing transmitter unit cables	7
Figure 5. Installing receiver unit cables	8
Figure 6. Chassis mounting options	10

## Tables

Table 1. Troubleshooting procedures .....	13
---	----

## Appendices

Appendix A — Specifications	16
-----------------------------	----

# INTRODUCTION

---

## Disclaimer

---

While every precaution has been taken in the preparation of this manual, the manufacturer assumes no responsibility for errors or omissions. Neither does the manufacturer assume any liability for damages resulting from the use of the information contained herein. The manufacturer reserves the right to change the specifications, functions, circuitry of the product, and manual content at any time without notice.

The manufacturer cannot accept liability for damages due to misuse of the product or other circumstances outside the manufacturer's control. The manufacturer will not be responsible for any loss, damage, or injury arising directly or indirectly from the use of this product (See limited warranty).

## System Introduction

---

Thank you for choosing the Rose Electronics CrystalLink USB-3-2-1 CATx extender.

The CrystalLink USB-3-2-1 CATx extender provides simultaneous transparent USB extension for all USB3.1, 2.0 and 1.1 devices up to 330 feet (100 meters) over a single CAT6a/7 UTP cable.

Up to four USB devices such as a USB3.1 conferencing camera, flash drives, hard drives, keyboards, mice, interactive white boards, touchscreens, docking stations, USB to video converters, audio devices, and/or any other USB3.1, 2.0 and 1.0 device can be extended away from the host PC using the CrystalLink USB-3-2-1 CATx extender. Additional USB devices can be connected using a powered USB hub.

The CrystalLink USB-3-2-1 CATx extension system consists of two units, a transmitter and a receiver. The transmitter connects to your computers' USB port. The transmitter is linked directly to the receiver using industry standard CAT6a/7 cable and the USB devices connect to the receiver.

To support the USB3.1 SuperSpeed of up to 5Gbps, the CrystalLink USB-3-2-1 CATx extender must be connected directly to the USB3.1 port of a host device.

The instructions in this manual assume a general knowledge of computer installation procedures, familiarity with cabling requirements, and some understanding of USB device operation.

## Features

---

- Supports a single CAT6a/7 cable up to 330 feet (100 meters)
- Supports transparent USB3.1 Gen 1 SuperSpeed data rates up to 5Gbps
- Supports all USB3.1, 2.0, 1.1 devices simultaneously at full bandwidth
- Backwards compatible with USB2.0 and USB1.1 devices
- Four USB3.1 Gen 1 receiver ports, each with up to 1.2 Amp (6W) power
- Attach up to 3 powered USB hubs for additional remote USB device support
- Ethernet 100/1000 pass-through for connecting to network enabled devices
- Plug and Play. No software drivers required
- Supports all major operating systems: Windows®, MAC OS™, Linux® and Chrome OS™
- Made in North America

## Package Contents

---

The package contents consist of the following:

- Transmitter unit
- Receiver unit
- USB3.1 Gen 1 cable
- 24V DC Power Adapter (2) and AC power cable (2). (Transmitter is 1A, Receiver is 2.71A)
- Installation & Operation Manual

## Additional Items Required

---

- USB compatible computer (host computer) with a USB compliant operating system
- USB compatible device(s) for remote-end connection
- Solid core CAT6a/7 Unshielded Twisted Pair (UTP) cable, shielded (STP) cable or foiled (FTP) cable up to a maximum of 330ft (100m).
- For optimum performance, the CAT6a/7 cable should be run straight and not coiled, and not routed close to electrical cables or radio interference. Terminate the cables according to T568A/T568B.

*All references to CAT6a/7 cable in this document refer to solid-core cable and represent the minimum CAT6a/7 specification requirements. Use of UTP/STP/FTP patch-cables may reduce the recommended cable extension distances.*

## Application Examples

---

The CrystalLink USB-3-2-1 CATx is ideal for use with USB3.1 conferencing cameras or in computer room or industrial environments where USB devices need to be connected remotely from a host PC.

- Industrial control
- Interactive whiteboard
- Connection to network attached devices
- Boardroom and conferencing presentations. Connect to a USB3.1 videoconferencing camera to provide video, control and power over a single CAT6a/7 cable
- Extension of multiple USB devices including hard drivers, printer, scanner, camera control, touchscreens

# MODELS

## CrystalLink USB-3-2-1 CATx Models

The CrystalLink USB-3-2-1 CATx enables users to extend beyond the standard 5m cable limit for USB peripherals by locating high-speed USB device(s) up to 330 feet (100 meters) from the computer.

### Transmitter Unit

The transmitter connects to the host device using the supplied USB3.1 Gen 1 cable. Power for the transmitter is provided by included 24V 1A power adapter. Power and status LED's are conveniently located on the front panel for user reference.

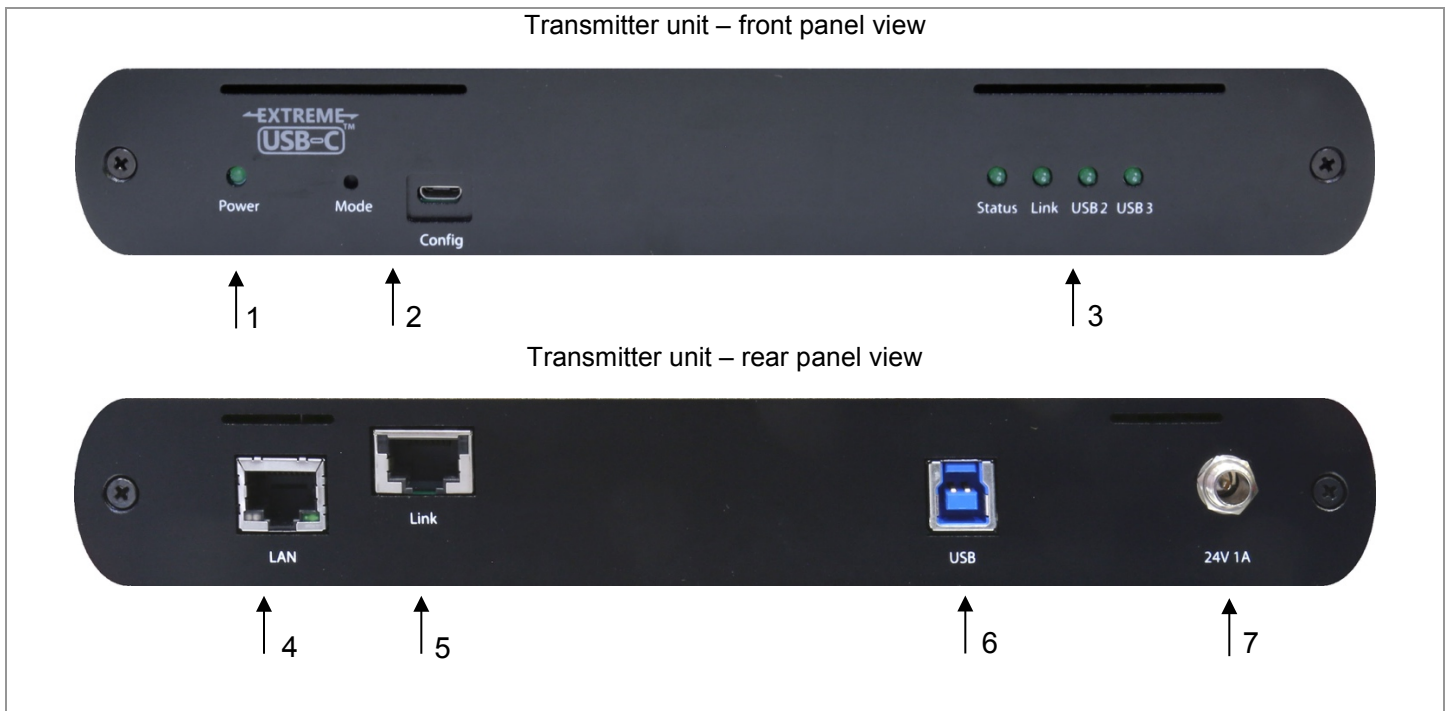

Item	Type	Description
1	Power LED	LED is SOLID ON when DC power is supplied to the extender unit. LED is OFF when no power is supplied by the AC adapter.
2	Mode/Config	Reserved for engineering use
3	Status LED	LED is SOLID ON when the system is functioning normally. LED BLINKS when the system is booting or to indicate a temperature warning together with the LINK, USB2, and USB3 LEDs.
	Link LED	LED is SOLID ON when the transmitter is linked to an opposite receiver unit. LED is OFF when there is no connection between the transmitter and receiver.
	USB2.0 LED	LED is SOLID ON when an active USB2.0 connection is established through the extender system. LED BLINKS when the USB2.0 connection is suspended/asleep. LED is OFF when no USB2.0 connection is detected.
	USB3.1 LED	LED is SOLID ON when an active USB3.1 connection is established through the extender system. LED BLINKS when the USB3.1 connection is suspended/asleep. LED is OFF when no USB3.1 connection is detected.
4	LAN port (100/1000 Mbps)	Ethernet pass through channel connects to a network or Ethernet device.

5	Link port (RJ45)	Accepts the RJ45 connector for CAT6a/7 cabling to connect the transmitter to the receiver.
6	USB host port	USB3.1 Type B connector used to connect the transmitter to the USB3.1 host computer.
7	DC power port	Locking connector for the included 24VDC 1A power adapter

Figure 1. transmitter unit – LED's and connectors

## Receiver Unit

The receiver has four USB3.1 Type-A ports for connecting up to four USB devices. Additional devices may be connected by attaching a USB hub to the receiver unit. The receiver is powered directly by the included 24V 2.71A power supply, delivering 1.2 Amp of current per USB port.

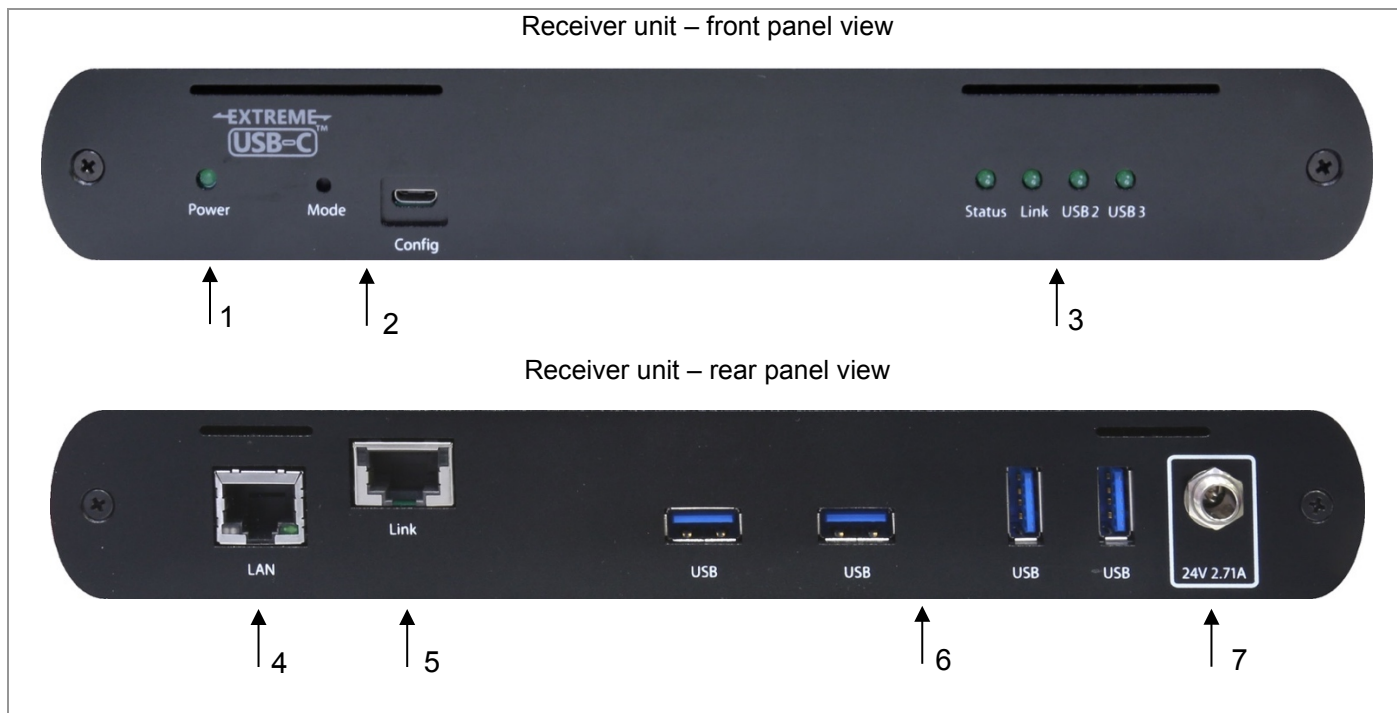

Item	Type	Description
1	Power LED	LED is SOLID ON when DC power is supplied to the extender unit. LED is OFF when no power is supplied by the AC adapter.
2	Mode/Config	Reserved for engineering use
3	Status LED	LED is SOLID ON when system is functioning normally. LED BLINKS when system is booting OR to indicate a temperature warning in unison with the LINK, USB2, and USB3 LEDs.
	Link LED	LED is SOLID ON when transmitter is linked to an opposite receiver. LED is OFF when there is no connection between the transmitter and receiver.
	USB 2 LED	LED is SOLID ON when an active USB 2 connection is established through the extender system. LED BLINKS when the USB 2 connection is suspended/asleep. LED is OFF when no USB 2 connection is detected.
	USB3 LED	LED is SOLID ON when an active USB3.1 connection is established through the extender system. LED BLINKS when the USB3.1 connection is suspended/asleep. LED is OFF when no USB3.1 connection is detected.



---

---

4	LAN Port (100/1000 Mbps)	Ethernet pass through channel connects to a network or Ethernet device.
5	Link Port (RJ45)	Accepts RJ45 connector for CAT6a/7 cabling to connect the transmitter to the receiver
6	Device Ports (USB3.1 Type A)	Accepts all USB devices.
7	DC Power Port	Locking connector for the included 24VDC 2.71A power adapter

**Figure 2. Receiver unit – LED's and connectors**

# INSTALLATION

## Installation Procedure

Before beginning an installation, ensure you have all products and components ready for the installation

### Cabling Requirements

The CrystalLink USB-3-2-1 CATx extender requires a minimum grade of Category 6a cabling to be used in order to reach 330ft (100m) of extension distance. For full distance extension, patch cable can be used up to 35ft (10m) only. The remaining 295ft (90m) must be solid core premise cabling.

When planning your installation, first determine the path of the link cable and whether to use Unshielded, Shielded or Foiled cable where appropriate.

When installing this product, it is appropriate to use Unshielded (UTP) cabling if the cable installation meets the following requirements:

- The cable is not bundled with other cables
- The cable is run loosely with other Category cables
- The cable is not placed close to sources of interference such as power lines and radios
- The cable is not looped or coiled

For optimum performance, Shielded (STP) or Foiled (FTP) cabling should be used if the cable installation encounters any of the following conditions:

- The cable is bundled with other cables
- The cable is run tight against other Category cables
- The cable is placed near sources of interference like power lines and radios
- The cable is looped or coiled

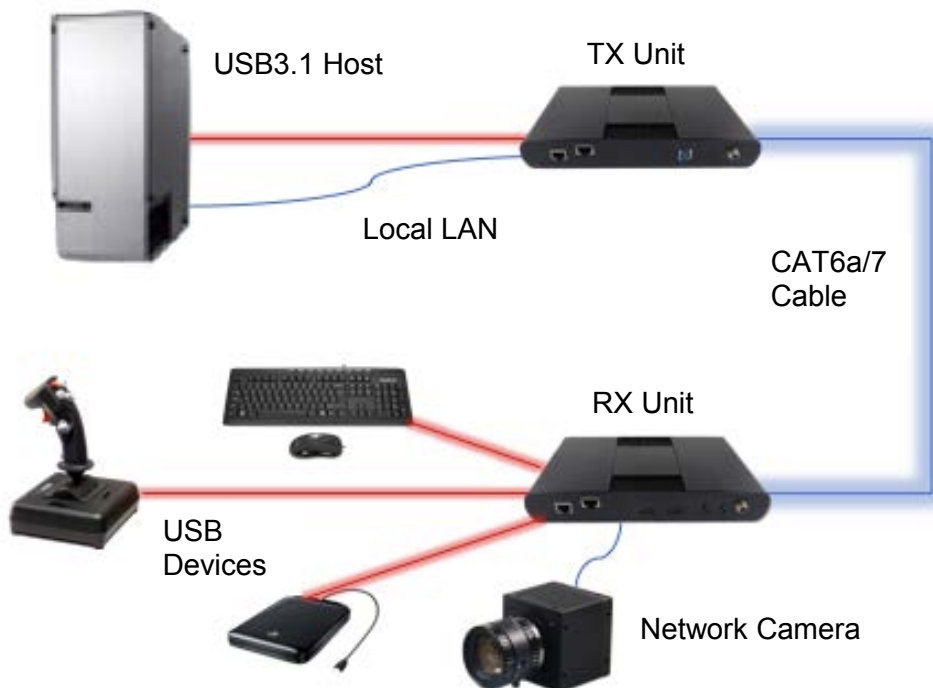

Figure 3. CrystalLink USB-3-2-1 CATx extender – standard installation

## Equipment Location

Before installing the CrystalLink USB-3-2-1 CATx extender, you will need to prepare your site and cable distance measurements.

- Place the computer in the preferred location and set it up.
- Ensure to locate your USB device(s) within the recommended CAT6a/7 cable-length from the computer. If not, adjust the location of your device(s) and/or computer accordingly.

Remember the product supports a maximum distance of 330ft (100m) for transparent USB devices. If using patch (stranded) cables or premise wiring, the achievable extension distance may be less.

Install the CAT6a/7 cabling as desired and terminate it with the appropriate RJ45 ends. If using premise cabling, (in-building network infrastructure), ensure your cabling is installed between the two locations and does not exceed 100m and that it meets the CAT6a/7 specification.

Cable installation is important, particularly if high throughput applications are used. When installing, ensure the cable is installed away from, or isolated from potential sources of interference such as electrical wiring, fluorescent lighting and radio or walkie-talkie signals.

When terminating cables, ensure the matching RJ45 connector is used for the cable type. For example, if CAT6a cable is used, then CAT6a compatible RJ45 connectors must be used. Otherwise, the benefits of using higher grade cabling may not be realized.

## Installing the Transmitter

- Place the transmitter unit near the computer.
- Assemble the power adapter and power cord together and connect them into a suitable AC outlet.
- Connect the supplied USB3.1 Gen 1 cable between the transmitter USB-B port and a USB3.1 port on the host computer.

Transmitter unit – cable connections



Local LAN Cable

CAT6a/7 Cable

USB-AB Cable

Power Cable

Figure 4. Installing transmitter unit cables

## Installing the Receiver

- Place the receiver unit near the USB device(s).
- Assemble the power adapter and power cord together and connect them into a suitable AC outlet.
- Connect the power adapter to the receiver.

Receiver unit – cable connectors



Local LAN Cable

CAT6a/7 Cable

USB Devices

Power Cable

Figure 5. Installing receiver unit cables

## Connecting the Transmitter to the Receiver

### With Surface Cabling:

- Plug one end of the CAT6a/7 cable (not included) into the link port on the transmitter.
- Plug the other end of the CAT6a/7 cable into the link port on the receiver.

### With Premise Cabling:

- Plug one end of a CAT6a/7 patch cord (not included) into the link port on the transmitter.
- Plug the other end of the patch cord into the CAT6a/7 information outlet near the host computer.
- Plug one end of the second CAT6a/7 patch cord (not included) into the link port on the receiver.
- Plug the other end of the patch cord into the CAT6a/7 information outlet near the USB device.

## Checking the Installation

On the transmitter and receiver units, check that the Power, Status, Link, USB 2 and USB3 LEDs are on. If the Link LEDs are permanently off, then the cabling between the local and transmitter may not be installed properly or is defective.

Check if the USB device is detected by your Operating System. (Note: If your computer does not correctly detect the USB device when it is attached to your computer, then it may not function correctly)

For Windows (XP, 7, 8, 8.1, 10) users, open Device Manager to confirm that the CrystalLink USB-3-2-1 extender has been installed correctly. Expand the entry for Universal Serial Bus controllers by clicking the “+” sign. You should find two separate instances of “Generic SuperSpeed USB Hub” listed.

To open Device Manager in Windows 2000/XP:

Right click on “My Computer”, then select Properties >>Hardware Tab>>Device Manager

To open Device Manager in Windows 7 and later:

Open the Start Menu, right click on “Computer” or the “Start Menu” then select Manage>>Device Manager

For MacOS users, open the System Profiler to confirm that the extender system has installed correctly. In the left-hand column under Hardware, select “USB” and inspect the right-hand panel. If the CrystalLink USB-3-2-1 extender has been installed correctly, you should find it listed as two separate instances of “Hub” under the USB SuperSpeed Bus.

To open the System Profiler in MAC OS X:

Open Finder, Select Applications, then open the Utilities folder and double click on the System Profiler icon.

If the CrystalLink USB-3-2-1 extender is not detected correctly or fails to detect, please consult the Troubleshooting section in this manual.

## Connecting a USB Device

- Install any software required to operate the USB device and refer to the product documentation for specific settings.
- Connect the USB device to the device port on the receiver
- Check that the device is detected and installed properly in the operating system.

## Compatibility

The CrystalLink USB-3-2-1 CATx complies with USB2.0 and USB3.1 Gen 1 specifications governing the design of USB devices. However, there is no guarantee that all USB devices or hosts will be compatible as there are a number of different characteristics that may impact the operation of USB devices over extended distances.

## Ethernet Pass-Through Connection

The CrystalLink USB-3-2-1 provides a 100/1000 Mbps Ethernet pass through connection that can be used for a variety of purposes including:

- Connecting network devices
- Providing remote network access to the same location as the transmitter
- Leveraging existing cabling to provide USB3.1, USB2.0 or USB1.1 connectivity without losing network connectivity

Connect any network device or access port into the RJ45-LAN port using up to 330ft (100m) of standard CATx LAN cabling

## Transmitter and Receiver Mounting Options

The bottom of the chassis includes four convenient pre-drilled holes for optional mounting. Based on your requirements, choose from two available mounting options:

- USB Extender Mounting Kit (Purchased separately - USB Mounting Kit - Black)
- USB Extender Direct Surface Mounting (Using your own rack-shelf or tray)

### **Option 1: CrystalLink USB-3-2-1 CATx Extender Mounting Bracket Kit**

#### Contents:

- 2 mounting brackets
- 4 (M3) locking washers
- 4 (M3 x 10mm) Phillips screws
- Mounting bracket installation guide (see diagram below)

1 kit required to mount per transmitter chassis or receiver chassis

Using a Phillips screwdriver, fasten and secure the provided screws, locking washers and brackets into place.

### **Option 2: CrystalLink USB-3-2-1 CATx Extender Mounting Plate**

(using your own rack-shelf or rack-tray) The bottom of the enclosure features four pre-drilled holes for optional surface mounting.

Note: Do not exceed a screw depth of 0.4" (10mm) into the chassis or damage may occur

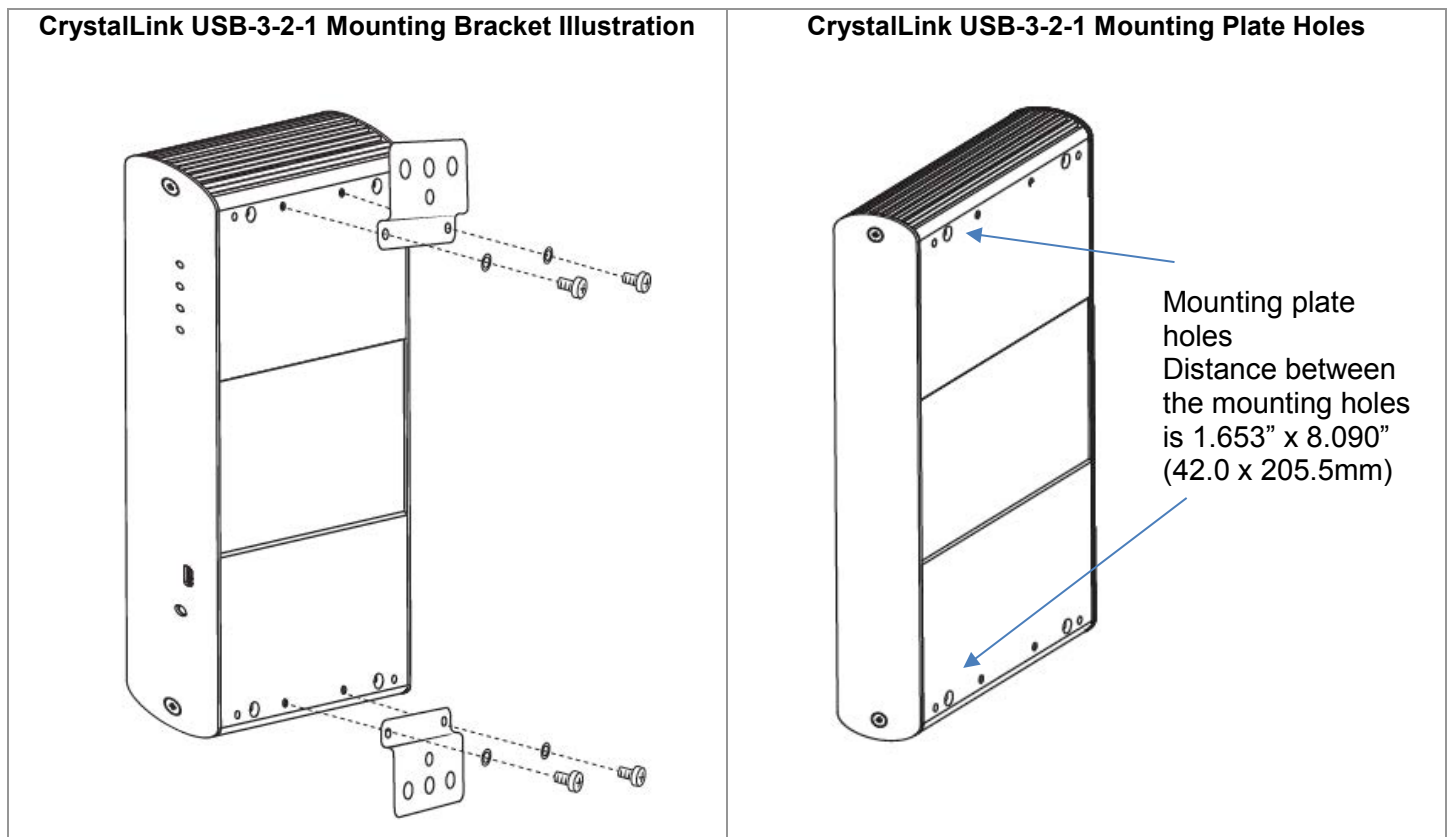

Figure 6. Chassis mounting options

# TROUBLESHOOTING

## Troubleshooting

The following table provides troubleshooting tips. The topics are arranged in the order in which they should be executed in most situations. If you are unable to resolve the problem after following these instructions, please contact Technical Support for further assistance.

PROBLEM	CAUSE	SOLUTION
ALL LEDs are OFF on the transmitter and/or receiver.	<ul style="list-style-type: none"><li>▪ The transmitter and/or receiver is not receiving power from the AC power adapter.</li></ul>	<ul style="list-style-type: none"><li>▪ Ensure that the AC power adapter is properly connected to the transmitter and/or receiver.</li><li>▪ Check that the AC adapter is connected to a live source of AC power. Check that the transmitter and/or receiver's Power LED is illuminated.</li></ul>
POWER LED is ON, STATUS LED is OFF.	<ul style="list-style-type: none"><li>▪ The unit has malfunctioned and requires re-programming.</li></ul>	<ul style="list-style-type: none"><li>▪ Contact Technical Support for assistance.</li></ul>
Link LEDs on the transmitter and receiver are OFF.	<ul style="list-style-type: none"><li>▪ There is no connection between the transmitter and receiver.</li></ul>	<ul style="list-style-type: none"><li>▪ Ensure that no more than 100m of CAT6a/7 cabling is connected between the transmitter and receiver.</li><li>▪ Connect a short patch cable between the transmitter and receiver. Recheck the link status. If the LINK LED is now SOLID ON, the previous cable is defective or not capable of supporting the link.</li></ul>
LINK LEDs on the transmitter and receiver are SOLID ON, but the USB2 and USB3 LEDs are OFF.	<ul style="list-style-type: none"><li>▪ The host computer is not powered on.</li><li>▪ The transmitter is not connected to a computer.</li><li>▪ The host computer does not support USB Hubs.</li><li>▪ The unit is malfunctioning.</li></ul>	<ul style="list-style-type: none"><li>▪ Disconnect all USB devices from the receiver.</li><li>▪ Disconnect transmitter from the host computer.</li><li>▪ Disconnect AC adapters from transmitter and receiver.</li><li>▪ Reconnect the transmitter to the host computer.</li><li>▪ Reconnect the AC adapters to the transmitter and receiver.</li><li>▪ Check that the transmitter and receiver have enumerated as USB hubs in Windows Device Manager, MacOS System Profiler or using "Isusb" command in a Linux Terminal.</li><li>▪ If the problem is not resolved, contact Technical Support.</li></ul>
The USB2 LED is SOLID ON, but the USB3 LED is OFF.	<ul style="list-style-type: none"><li>▪ The transmitter is not connected to a USB3.1 port.</li><li>▪ The transmitter is connected to the host using a USB2.0 cable.</li><li>▪ The USB3.1 cable connecting the transmitter to the host computer is defective.</li><li>▪ The host computer's USB3.1 controller has malfunctioned.</li></ul>	<ul style="list-style-type: none"><li>▪ Ensure that the transmitter is connected to a USB3.1 port on the host computer.</li><li>▪ Ensure that the included USB3.1 Gen 1 cable is being used between the host computer and transmitter.</li><li>▪ Cold boot the host computer.</li><li>▪ Replace the USB3.1 Gen 1 cable with a different cable.</li><li>▪ If the problem is not resolved, contact Technical Support.</li></ul>

PROBLEM	CAUSE	SOLUTION
The USB3 LED is SOLID ON, but the USB2 LED is OFF.	<ul style="list-style-type: none"> <li>▪ The USB cable connecting the transmitter to the host computer is defective.</li> <li>▪ The host computer's USB2.0 controller has malfunctioned.</li> <li>▪ The host computer does not support USB2.0.</li> </ul>	<ul style="list-style-type: none"> <li>▪ Ensure that the included USB3.1 Gen 1 cable is being used between the host computer and transmitter.</li> <li>▪ Cold boot the host computer.</li> <li>▪ Replace the USB3.1 Gen 1 cable with a different cable.</li> <li>▪ If the problem is not resolved, contact Technical Support.</li> </ul>
Both the transmitter and receiver are working, but the USB2 or USB3 LEDs on the transmitter and receiver are blinking.	<ul style="list-style-type: none"> <li>▪ The transmitter and/or receiver is in suspend mode. For a variety of reasons, the host computer may place the transmitter or receiver into suspend mode. Typically, it is because there are no USB devices attached, the USB device is asleep, or the host computer is in a sleep state or hibernating.</li> </ul>	<ul style="list-style-type: none"> <li>▪ Recover/resume the operating system from sleep or hibernate modes (refer to your operating system's documentation).</li> <li>▪ Connect a USB device to the receiver.</li> <li>▪ Use the connected device.</li> <li>▪ If the problem persists, contact Technical Support.</li> </ul>
ALL LEDs on both the transmitter and receiver are SOLID ON, but the USB device is not operating correctly, or is detected as an "Unknown Device" in the operating system.	<ul style="list-style-type: none"> <li>▪ The USB device is malfunctioning.</li> <li>▪ The computer does not recognize the USB device.</li> <li>▪ The application software for the USB device is not operating.</li> <li>▪ The USB extender is malfunctioning.</li> </ul>	<ul style="list-style-type: none"> <li>▪ Disconnect the transmitter from the computer.</li> <li>▪ Connect the USB device directly to the host computer.</li> <li>▪ If the device does not operate as expected, consult the user documentation for the device.</li> <li>▪ Update the host computer BIOS, chipset or USB controller drivers from the manufacturer's website.</li> <li>▪ If the device operates as expected when directly connected to the computer, connect another device to the extender and reconnect it to the host computer.</li> <li>▪ If the second device does not operate, the extender may be malfunctioning. Contact Technical Support for assistance.</li> <li>▪ If the second device operates as expected, then the first device may not be compatible with this extender. Contact Technical Support.</li> </ul>



PROBLEM	CAUSE	SOLUTION
A USB3.1 device is not enumerating as USB3.1, or the operating system is notifying the user that the device can "Perform Faster if connected to a USB3.1 port".	<ul style="list-style-type: none"> <li>▪ The USB device is malfunctioning.</li> <li>▪ The computer does not recognize the USB device.</li> <li>▪ The application software for the USB device is not operating.</li> <li>▪ The USB3.1 port on the computer is malfunctioning.</li> <li>▪ The USB extender is malfunctioning.</li> </ul>	<ul style="list-style-type: none"> <li>▪ Disconnect the transmitter from the computer.</li> <li>▪ Connect the USB3.1 device directly to the host computer.</li> <li>▪ If the device does not operate as expected as a USB3.1 device, consult the user documentation for that device or try a different USB port on the host computer.</li> <li>▪ Update the host computer BIOS, chipset or USB controller drivers from the manufacturer's website.</li> <li>▪ If the device operates as a USB3.1 device when directly connected to the computer, connect another USB3.1 device to the extender and reconnect it to the host computer.</li> <li>▪ If the second device does not operate as a USB3.1 device, the extender may be malfunctioning. Contact Technical Support for assistance.</li> <li>▪ If the second device operates as a USB3.1 device as expected, the first device may not be compatible with this extender. Contact Technical Support.</li> </ul>
All LEDs are flashing, and the system is operational.	<ul style="list-style-type: none"> <li>▪ Unit is or was operating at an unsafe temperature.</li> </ul>	<ul style="list-style-type: none"> <li>▪ Check ambient temperature. Ensure temperature does not exceed 50°C (122°F). Power cycle the unit to remove LED status.</li> </ul>
All LEDs are flashing, and the system is NOT operational.	<ul style="list-style-type: none"> <li>▪ Unit has exceeded safe operating temperature.</li> </ul>	<ul style="list-style-type: none"> <li>▪ Remove external sources of heat or change location of the unit.</li> <li>▪ Power cycle the unit to return to operation.</li> </ul>
LEDs are scrolling LEFT to RIGHT, starting with STATUS.	<ul style="list-style-type: none"> <li>▪ Unit is programming.</li> </ul>	<ul style="list-style-type: none"> <li>▪ Wait for the unit to finish programming.</li> </ul>

**Table 1. Troubleshooting procedures**

# PRODUCT SAFETY

---

---

## Safety

---

The CrystalLink USB-3-2-1 CATx extender, like all electronic equipment, should be used with care. To protect yourself from possible injury and to minimize the risk of damage to the Unit, read and follow these safety instructions.

- Follow all instructions and warnings marked on this Unit.
- Except where explained in this manual, do not attempt to service this Unit yourself.
- Do not use this Unit near water.
- Assure that the placement of this Unit is on a stable surface.
- Provide proper ventilation and air circulation.
- Keep connection cables clear of obstructions that might cause damage to them.
- Use only power cords, power adapter and connection cables designed for this Unit.
- Keep objects that might damage this Unit and liquids that may spill, clear from this Unit. Liquids and foreign objects might come in contact with voltage points that could create a risk of fire or electrical shock.
- Do not use liquid or aerosol cleaners to clean this Unit. Always unplug this Unit from the power source before cleaning.

Remove power from the unit and refer servicing to a qualified service center if any of the following conditions occur:

- The connection cables are damaged or frayed.
- The Unit has been exposed to any liquids.
- The Unit does not operate normally when all operating instructions have been followed.
- The Unit has been dropped or the case has been damaged.
- The Unit exhibits a distinct change in performance, indicating a need for service.

# SERVICE AND MAINTENANCE

---

---

## Maintenance and Repair

---

This Unit does not contain any internal user-serviceable parts. In the event a Unit needs repair or maintenance, you must first obtain a Return Authorization (RA) number from Rose Electronics or an authorized repair center. This Return Authorization number must appear on the outside of the shipping container.

See Limited Warranty for more information.

When returning a Unit, it should be double-packed in the original container or equivalent, insured and shipped to:

Rose Electronics

Attn: RA \_\_\_\_\_

10707 Stancliff Road

Houston, Texas 77099 USA

## Technical Support

---

If you are experiencing problems, or need assistance installing your product, consult the appropriate section of this manual. If, however, you require additional information or assistance, please contact the Rose Electronics Technical Support Department at:

Phone: (281) 933-7673

E-mail: [TechSupport@rose.com](mailto:TechSupport@rose.com)

Web: [www.rose.com](http://www.rose.com)

Technical Support hours are from: 8:00 am to 6:00 pm CST (USA), Monday through Friday.

Please report any malfunctions in the operation of this Unit or any discrepancies in this manual to the Rose Electronics Technical Support Department.

---

# APPENDICES

## Appendix A – Specifications

Part Numbers		Description
CLK-4U321TP-100M		CrystalLink USB-3-2-1 CATx extender
RM-UD/CLK321		Rackmount "L" bracket for mounting TX or RX unit on a shelf, under desk, or flat surface. (Not for 19" rack)
Chassis Dimensions (W x D x H) and Weight		
Transmitter and Receiver chassis Weight	9.1" x 5.4" x 1.3" (232 x 137.3 x 33 mm) 5.87lbs (2.67kg)	
Power Requirements		
Power source	Transmitter: 100-240VAC, AC input, 24V 1A DC output Receiver: 100-240VAC, AC input, 24V 2.71A DC output	
Maximum current for USB devices	Receiver: Up to 1.2 Amp (6W) per USB port	
Interconnect Cable Requirements		
CAT6a/7, RJ45	CAT6a/7 solid core, UTP, STP or FTP, terminated as EIA/TIA 568-B	
Cable Distances		
CAT6a/7 cable	Up to 330 feet (100 meters) over solid core CAT6a/7 cable. Use of patch cable may reduce the operating distance	
USB Support		
USB Bandwidth	Up to 5Gbps	
USB Device Support	Gen 1 USB3.1 devices at 5Gbps (all device types and hubs) High-speed devices (USB 2.0) at 480Mbps, backwards compatible Full-speed devices (USB 1.1), 12Mbps, backwards compatible	
USB Hub Support	Up to 3 powered USB hubs with 26 USB devices. The extension distance may be reduced with each hub added to the system.	
USB Host Support	XHCI (USB3.1), EHCI (USB 2.0) and OHCI/UHCI (USB 1.1) USB3.1 host supported at up to 5Gbps	
Connectors and LED's		
	Transmitter unit	Receiver unit
USB connector	1 x USB3.1 Gen 1 Type B	4 x USB3.1 Gen 1 Type A female
Link cable connector	1 x RJ45 Link	1 x RJ45 Link
Network Pass Through	1 x RJ45 100/1000 LAN Port	1 x RJ45 100/1000 LAN Port
LED's	Power, Status, Link, USB2, USB3	Power, Status, Link, USB2, USB3
Environmental		
Operating Temp	32°F to 122°F (0°C to 50°C)	
Storage Temp	-4°F to 158°F (-20°C to 70°C)	
Operating Humidity	20% to 80% relative, non-condensing	
Storage Humidity	10% to 90% relative, non-condensing	
Approvals	FCC Part 15 Class B, CE Class B, ICES-003 Class B, EMC EN55022, EN55024, EN55032 and EN61000, RoHS2 (CE), WEEE	

ROSE.COM

---

**WWW.ROSE.COM** ▪ **sales@rose.com** ▪ **(800) 333-9343**

Rose Electronics ▪ 10707 Stancliff Road ▪ Houston, Texas 77099  
Rose USA (281) 933-7673 ▪ Rose Europe +49 (0) 2454 969442  
Rose Asia +65 6324 2322 ▪ Rose Australia +61 (0) 421 247083



**WWW.ROSE.COM**